

BADU[®] Dual Speed

Dual speed energy efficient pool and pool heating pump for a variety of uses.



Includes: Dual Speed Switch

3.5-Star Energy Rating

Average energy consumption of \$35 per month

Flow Rate up to 260 lpm on High Speed

Quieter, smoother performance

German design & engineering

5 Year Warranty*

Robust 2.0 HP motor

Easy to remove non-corrosive lid with handle

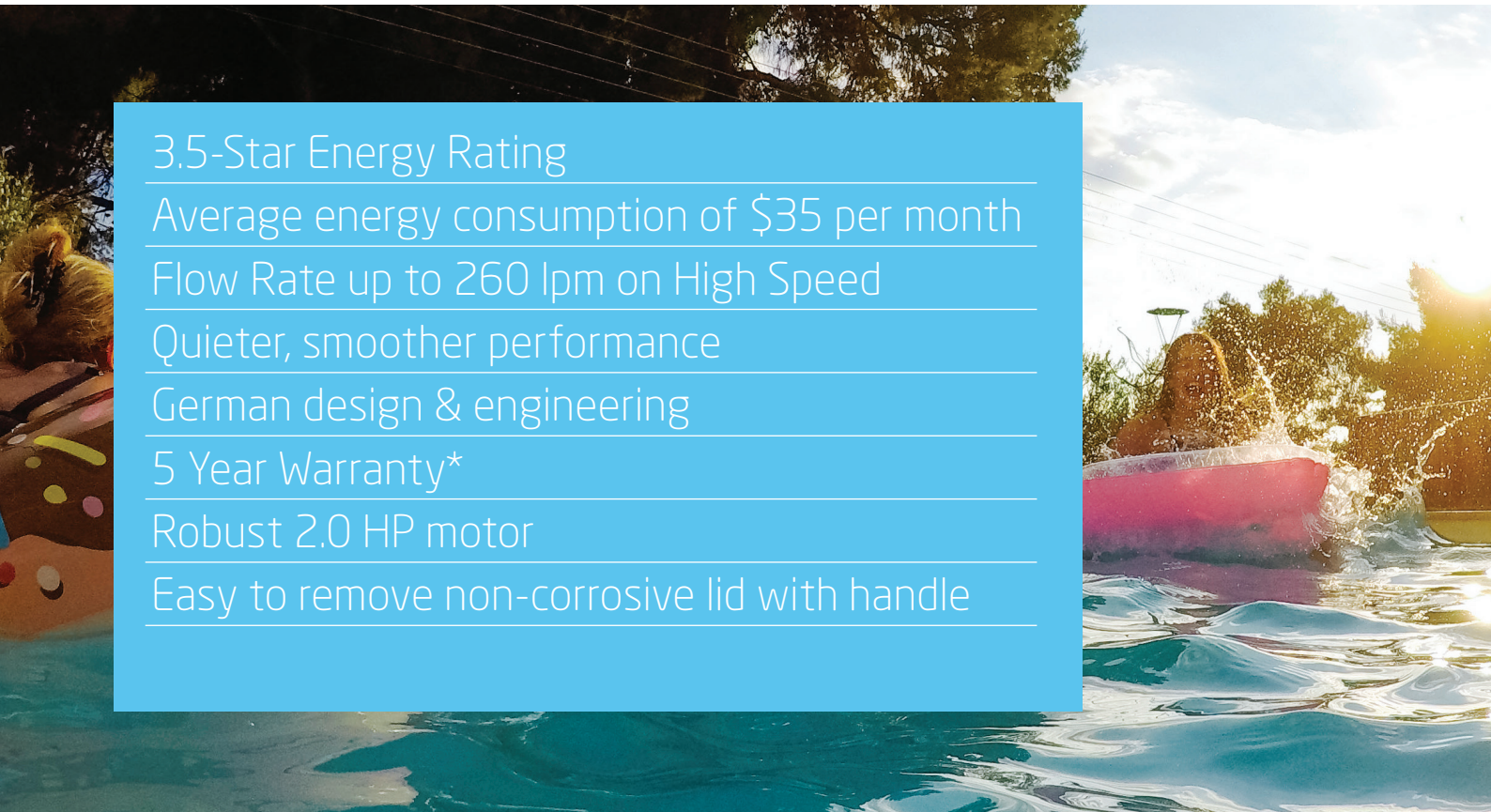



The Speck 90/500 DS is the ideal choice for all domestic pool and pool heating applications where high flow rates are required.

Features:

- > A high resistance to corrosion and salt water
- > The ultimate in reliability
- > No contact between motor and pump shaft with pool or spa water
- > Highest quality mechanical seal
- > Fan cooled - suitable for high ambient temperatures
- > Closed impeller
- > Stainless steel motor shaft
- > Easy to remove clear strainer lid
- > Every pump factory wet tested for quality control

| 90/500DS | |
|------------------------|--------------|
| Head Max/Min - m | 13/3 |
| Inlet Connection - mm | 50 |
| Outlet Connection - mm | 40 |
| Motor Speed - RPM | 2670/1350 |
| Power Input - V | 240 |
| Power Output - watts | H 1332/L 276 |
| AMPS | H 5.8 /L 1.2 |
| Weight - kg | 22 |
| Max Water Temp - Deg.C | 40 |
| Sound DBA | 60/60 |

WARRANTY

* Five (5) Year Factory Warranty on the following wet end components: Casing, Diffuser, Gland Housing, Impeller and Mechanical Seal. Two (2) Year Warranty on motor and in all commercial applications. The pouring of salt and chemicals directly into the skimmer box will void full warranty.

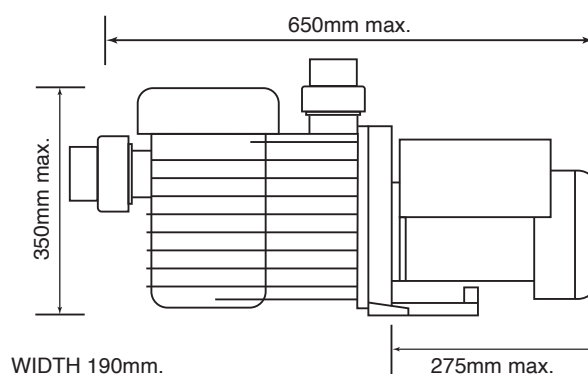
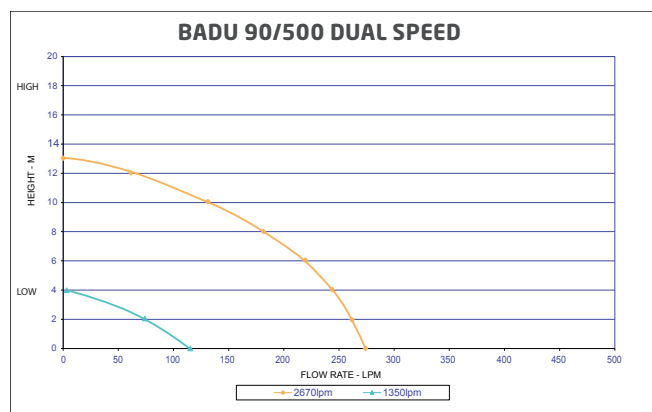

SALES & SERVICE 1300 280 323 | sales@speckpool.com.au | info@speckpool.com.au

New South Wales Office
t (02) 8814 2800
f (02) 9838 7030

Victorian Office
t (03) 8794 3800
f (03) 9702 3941

Queensland Office
t (07) 3434 1100
f (07) 3219 2266

New Zealand Office
t 0011 64 9570 9570
f 0015 64 9527 7641