

BADU[®] EcoDrive VS

The 6-Star energy saving pump with variable speed motor for lower cost and quieter operation.



Control Panel replicated to show screen detail



6-Star Energy Rating for Ultimate Energy Savings
Lower Noise Levels
5 Year Warranty*
Lower Carbon Footprint
German Design & Engineering



Thanks to its 6-Star energy rating, the highly efficient BADU EcoDrive VS is setting the standard compared to a conventional induction motor pump. The operating costs and the CO₂ emissions are significantly lower in comparison with a standard pump meaning the pump pays for itself in less than two years!

- > Patented permanent magnet motor, with axil rotor, referred to as DC Motor, perfected for use in swimming pools and spa filter systems
- > Simple and brilliant - the lower the motor speed the lower the energy consumption
- > Settings can be selected using a user-friendly control panel
- > Separate interface to allow for external touch free control (optional extra)
- > Designed for quiet operation
- > Stainless steel shaft and 100% recyclable plastics for corrosion and salt water resistance
- > Motor double sealed for total separation between the pool water and pump shaft
- > Suitable for pools with a maximum salt level of 5,000 ppm
- > Every pump factory wet tested for quality control

EcoDrive VS	
Head Max/Min - m	15/1
Inlet Connection - mm	50
Outlet Connection - mm	40
RPM Max/Min	2850/1000
Power Input - V	240
Power Input - watts	975
Power Output - watts	750
Weight - kg	25
Max Water Temp - Deg.C	40

Preset	Max Amp Draw	RPM
Low	4.1	1900
Medium	5.1	2400
High	6.5	2850

WARRANTY

* Five (5) Year Factory Warranty on the following wet end components: Casing, Diffuser, Gland Housing, Impeller and Mechanical Seal. Two (2) Year Warranty on motor and in all commercial applications. The pouring of salt and chemicals directly into the skimmer box will void full warranty.

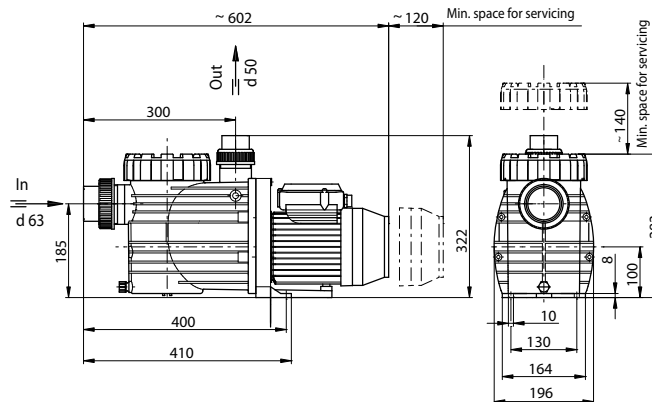
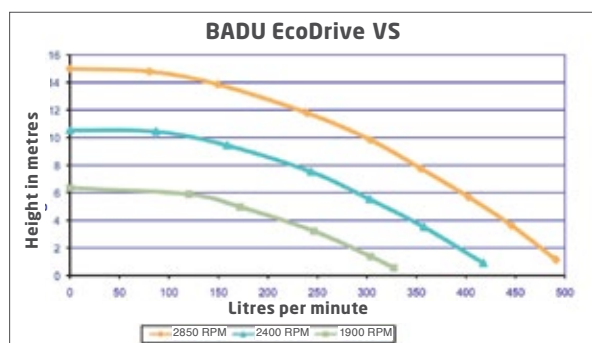

SALES & SERVICE 1300 280 323 | sales@speckpool.com.au | info@speckpool.com.au

New South Wales Office
 t (02) 8814 2800
 f (02) 9838 7030

Victorian Office
 t (03) 8794 3800
 f (03) 9702 3941

Queensland Office
 t (07) 3434 1100
 f (07) 3219 2266

New Zealand Office
 t 0011 64 9570 9570
 f 0015 64 9527 7641